



[Sitemap](#) | [Contact Us](#)

Emergency Information

[Children](#) | [Earthquake](#) | [Evacuation](#) | [Family](#) | [Fire](#) |
[First Aid](#) | [Food](#) | [Grab N' Go Bag](#) | [Home Safety](#) |
[Power Outage](#) | [Phones](#) | [Seniors](#) | [Sirens](#) | [Storms](#) |
[Terrorism](#) | [Tornado](#) | [Utilities](#) | [Water](#) |

This is by no means a comprehensive list of precautions, supplies, web sites or possible disasters. It is our attempt to try and put together a "one stop" place where you can get good basic information on planning for, reacting to and surviving some of the most common man-made and natural disasters that can occur in the Midwest. If you find a web page, pamphlet or book that you think would be a good addition to this page please send or [email](#) us the information.

(Our mailing address is: City of Rolla (Attn. IT Dept), PO Box 979, Rolla, MO 65402)



Children (Also see [Family](#) | [Grab N' Go Bag](#))

Plan:

- Include your children in family discussions and planning for emergency safety.
- Teach your children their basic personal information so they can identify themselves and get help if they become separated from a parent or guardian.
- Prepare an [emergency card](#) and [Family Communications Worksheet](#) with information for each child, including his/her full name, address, phone number, parent's work number and out of state contact.
- Know the policies of the school or daycare center your children attend. Make plans to have someone pick them up if you are unable to get to them.
- Regularly update your child's school with current emergency contact information and persons authorized to pick up your child from school.
- Make sure each child knows the family's alternate meeting sites if you are separated in a disaster and cannot return to your home.

- Make sure each child knows how to reach your family's out-of-state contact person.
- Teach children to dial their home telephone number and Emergency 9-1-1.
- Teach children what gas smells like and advise them to tell an adult if they smell gas after an emergency.
- Warn children never to touch wires on poles or lying on the ground.
- Role-play with children to help them remain calm in emergencies and to practice basic emergency responses such as evacuation routes, Drop, Cover & Hold and Stop, Drop & Roll.
- Role-play with children as to what they should do if a parent is suddenly sick or injured.
- Role-play with children on what to say when calling Emergency 9-1-1.

Kit:

- Include a current copy of your [Emergency Contact Sheet](#) or a [Family Communications Plan worksheet](#)
- Include a family picture and a favorite toy, game or book for each child in his/her Go-bag.
- Include your child's emergency card and include information on reunification locations and out-of-area contact.
- Provide comfort food and treats for each child in your family disaster supplies kit.
- Keep a recent photo of your children in your [Grab N' Go-bag](#).

[| Back to the EMERGENCY home page |](#)



Earthquake (Also see [Fire](#) | [Grab-N-Go bag](#) |

Utilities)

[FEMA web info on Earthquakes](#)

- If you are indoors during an earthquake, drop, cover, and hold on. Get under a desk, table or bench. Hold on to one of the legs and cover your eyes. If there's no table or desk nearby, sit down against an interior wall. An interior wall is less likely to collapse than a wall on the outside shell of the building.
- Pick a safe place where things will not fall on you, away from windows, bookcases, or tall, heavy furniture.
- It is dangerous to run outside when an earthquake happens because bricks, roofing, and other materials may fall from buildings during and immediately following earthquakes, injuring persons near the building.
- Wait in your safe place until the shaking stops, then check to see if you are hurt. You will be better able to help others if you take care of yourself first, then check the people around you.
- Move carefully and watch out for things that have fallen or broken, creating hazards. Be ready for additional earthquakes called "aftershocks."

- Be on the lookout for fires. Fire is the most common earthquake related hazard, due to broken gas lines, damaged electrical lines or appliances, and previously contained fires or sparks being released.
- If you must leave a building after the shaking stops, use the stairs, not the elevator. Earthquakes can cause fire alarms and fire sprinklers to go off. You will not be certain whether there is a real threat of fire. As a precaution, use the stairs.
- If you are outside in an earthquake, stay outside. Move away from buildings, trees, streetlights, and power lines. Crouch down and cover your head. Many injuries occur within 10 feet of the entrance to buildings. Bricks, roofing, and other materials can fall from buildings, injuring persons nearby. Trees, streetlights, and power lines may also fall, causing damage or injury.

[| Back to the EMERGENCY home page |](#)



Evacuation

Immediate risk:

If you smell gas, smoke or see fire or otherwise fear for your safety, evacuate household occupants immediately. From a safe location, call 9-1-1 and report the incident.

General evacuation orders:

If local officials issue evacuation orders, use the evacuation routes and methods specified; carpool whenever possible. If time allows:

- Wear sturdy shoes, long-sleeve shirts and pants.
- Bring car keys, credit cards, road maps, cell phone, charger and important phone numbers.
- Bring your [Grab N' Go bag](#).
- If you have a pet, make sure it is wearing a collar, bring it in a pet carrier labeled with your name and the pet's name. Bring pet food.
- Lock your home and shut off the water and electricity, but leave gas on unless instructed otherwise.
- Once you arrive at a safe location, call your out-of-area [emergency contact](#).

Disaster Shelters

Immediately following a large disaster, suitable shelter sites will be selected from a predesignated list based on areas of need and estimated numbers of displaced persons. Each site must be inspected for safety prior to being opened to the public. Therefore, it is not possible to say with advance certainty which sites will actually operate as disaster shelters. As soon as disaster sites have been formally designated, this list will be announced through local media to the public. If it is unsafe to shelter-in-place, and you do not have an alternative, evacuate to a designated emergency shelter.

- Tell your out-of area-contact where you are going.
- Take your [Grab N' Go bag](#) with you to the shelter.

- Initially, emergency shelters may not be able to provide basic supplies and materials. Consider bringing extra items (e.g. blanket, pillow, air mattress, towel, washcloth, diapers, food and supplies for infants.)

[| Back to the EMERGENCY home page |](#)



Family (Also see: [Children](#) | [Grab N' Go bag](#))

Talk with your family about potential disasters and why it's necessary to prepare for them. Involve each member of your family in the planning process. By showing them simple steps that can increase their safety, you can help reduce their fear of emergencies.

- Make sure everyone knows where to find your disaster supply kit and [Grab N' Go bags](#).
- Plan where to meet after a disaster if your home becomes unsafe. Choose two places, one just outside your home and one outside your neighborhood in case you are told to evacuate. Be sure your gas tank is always at least half full.
- Determine the best escape routes from your home. Try to identify two escape routes.
- Make sure each member knows who your family's out-of-state contact is and instruct them to call this person and tell him/her where they are.
- Locate the gas main and other [utilities](#) and make sure family members know when and how to turn them off.
- Practice your evacuation routes, Drop, Cover & Hold and Stop, Drop & Roll drills.
- Teach each member of your family how to use a fire extinguisher.
- Create emergency response cards for each of your family members.
- Take into account the special needs of [children](#), seniors or people with disabilities, family members that don't speak English and pets.

[| Back to the EMERGENCY home page |](#)



Fire

[| FEMA web info](#) | [| Fire Safety](#) | [| Fire Safety publications](#) | [| Fire Prevention](#) |

If your smoke detector goes off or you see a fire:

- MOST IMPORTANTLY REMAIN CALM & GET OUT...POSSESSIONS CAN BE REPLACED BUT PEOPLE CAN'T.
- If you see smoke under the door, find another way out.

- Feel the door with the back of your hand before you open it. If it is hot, find another way out.
- Drop to the floor to avoid smoke and fumes. Crawl to safety.
- If your clothes catch on fire, STOP where you are, DROP to the ground, and ROLL over and over to smother the flames.
- Call 9-1-1 from a safe location.
- If you are trapped in a burning building, stay near a window and close to the floor. If possible, signal for help.

[| Back to the EMERGENCY home page |](#)



First Aid

[| First Aid | First Aid Kits |](#)

In any emergency, you or a family member may be cut, burned or suffer other injuries. Keep the following basic first aid supplies so you are prepared to help when someone is hurt.

- Disposable gloves
- Sterile dressings to stop bleeding
- Cleansing agent/soap and antibiotic towelettes to disinfect
- Antibiotic ointment to prevent infection
- Burn ointment
- Adhesive bandages in a variety of sizes
- Eye wash solution to flush the eyes or as general decontaminant
- Scissors
- Tweezers
- Needles
- Moist towelettes
- Safety pins
- Thermometer
- Over-the-counter medicines such as Aspirin or other pain reliever, laxative, anti-diarrhea medication
- Prescription medications you take every day such as insulin, heart medicine, or asthma inhaler
- Prescribed medical supplies such as glucose monitoring equipment or blood pressure monitors



[| Back to the EMERGENCY home page |](#)



Food (Also see [Power Outage](#))

When a disaster occurs, you might not have access to food, water and electricity for days, or even weeks. Store enough emergency food to provide for your family for at least 3 days.

- After a power outage, refrigerated food will stay cold longer if you keep the door closed. Food should generally be consumed within 4 hours. Food in the freezer will normally remain safe for 2 days.
- Store food items that are familiar, rather than buying special emergency food. Consider any dietary restrictions and preferences you may have.
- Ideal foods are: Shelf-stable (no refrigeration required), low in salt, and do not require cooking (e.g. canned fruit, vegetables, peanut butter, jam, low-salt crackers, cookies, cereals, nuts, dried fruit, canned soup or meats, juices and non-fat dry milk).
- Mark a rotation date on any food container that does not already have an expiration date on the package.
- Include baby food and formula or other diet items for infants or seniors.
- Store the food in airtight, pest-resistant containers in a cool, dark place.
- Most canned foods can safely be stored for at least 18 months. Low acid foods like meat products, fruits or vegetables will normally last at least 2 years. Use dry products, like boxed cereal, crackers, cookies, dried milk or dried fruit within six months.

[| Back to the EMERGENCY home page |](#)



Grab N' Go Bag (Also see [First Aid](#))

A component of your disaster kit is your Go-bag. Put the following items together in a backpack or another easy to carry container in case you must evacuate quickly. Prepare one Go-bag for each family member and make sure each has an I.D. tag. You may not be at home when an emergency strikes so keep some additional supplies in your car and at work, considering what you would need for your immediate safety.

- Flashlight
- Radio – battery operated
- Batteries (for flashlights & radio)
- Whistle
- Dust mask
- Pocket knife
- Emergency cash in small denominations and quarters for phone calls
- Sturdy shoes, a change of clothes, and a warm hat

- Local map
- Some water and food
- Permanent marker, paper and tape
- Photos of family members and pets for re-identification purposes
- List of emergency point-of-contact phone numbers
- Pre paid long-distance calling card
- List of allergies to any drug (especially antibiotics) or food
- Copy of health insurance and identification cards
- Extra prescription eye glasses, hearing aid or other vital personal items
- Prescription medications and first aid supplies
- Toothbrush and toothpaste
- Extra keys to your house and vehicle
- Any special-needs items for **children**, seniors or people with disabilities.

[| Back to the EMERGENCY home page |](#)



Home Safety

[| Home Safety Council | Home Safety Checklist |](#)

During a disaster, ordinary objects in your home can cause injury or damage. However, there are simple steps you can take to make your home safer. Start by viewing each room with a "disaster eye" and identify potential hazards – bookshelves that could tip over in an earthquake and block exits or heavy objects that could fall and cause injury.

- Install smoke detectors on each level of your home and change batteries every 6 months.
- Move beds away from windows.
- Move mirrors and heavy pictures away from couches or places where people sit.
- Clear hallways and exits for easy evacuation.
- Store heavy items on the lowest shelves.
- Keep an ABC type fire extinguishers on each level and know how and when to use them.
- Strap down your water heater and fit all gas appliances with a flexible gas supply line.
- Store flammable or highly reactive chemicals (such as bleach, ammonia, paint thinners) securely and separate from each other.
- Secure pictures and wall hangings and use restraints to secure heavy items such as bookcases and file cabinets.
- Know how and when to switch off your [utilities](#).
- Ensure that all window safety bars have emergency releases.
- Be sure your home number is visible from the street so emergency vehicles can find you.

[| Back to the EMERGENCY home page |](#)



Phones (See also [Emergency Contacts](#))

Plan for how you will communicate with loved ones after a disaster.

- Print and fill out a [Family Communications Plan worksheet](#)
- Long-distance phone lines often work before local phone lines, so identify an out-of-state contact and provide this person with the contact information of people you want to keep informed of your situation. Share this information with your family and friends locally.
- Cordless phones or phone systems require electricity, so make sure you have a backup phone that requires no electricity.
- Avoid making non-urgent phone calls after a disaster – even if phone lines are un-damaged, increased phone traffic can jam phone circuits.
- Don't count on your cell phone - if land lines have been damaged then everyone will be trying to use their cell phones and the increased traffic on cell phone networks can quickly overload wireless capacity. Record an outgoing message on your voicemail so that callers can be re-assured of your safety status.
- Keep coins in your [Grab N' Go bag](#). Payphones are more likely to work before other phone lines.
- After an earthquake, check all your telephones to be sure they have not shaken off the hook and are tying up a line.

[| Back to the EMERGENCY home page |](#)



Power Outage

With power lines exposed at the top of tall skinny poles, many things can cause the wire to be cut or knocked down. High winds, ice or even a car hitting the pole are some of the most common things that cause power outages over relatively small areas. Some extreme conditions such as earthquakes or tornadoes can cause power loss over very widespread areas.

If there is no power in your neighborhood:

- Turn off and unplug appliances and computers. Leave one light on to indicate when power has been restored.
- Avoid using candles (unless necessary), as they are fire hazards.
- Do not use a gas stove for heating or operate generators indoors (including the garage.) Both could cause carbon monoxide poisoning.
- If a traffic signal is not working, treat it as a stop sign.
- See the [Food](#) section to learn about food safety when your refrigerator's power is off.

| [Back to the EMERGENCY home page](#) |



Sirens (Also see [Tornado](#))

Testing vs Real Emergency:

TESTING: The sirens are tested once a month. It will be on the 1st Wednesday of each month at 10:00 am (unless there is bad weather, then we skip the test so as not to confuse anyone about being real or a test).

EMERGENCY: We only set the sirens off when there is a **confirmed sighting of a tornado** in our area (or within an adjoining county heading our direction) or the National Weather Service sends us a teletype stating that there is tornadic activity, showing up on their radar, in our area.

The sirens will NOT be set off because we are under a watch or warning. **What that means is that when we set them off it is time to take shelter immediately.** That would not be the time to turn on the weather channel and see what's going on.

Tornado Watch vs Warning

WATCH: means weather conditions are favorable for severe weather storms or tornadoes.

WARNING: means severe weather, storms/tornadoes have been sighted and are in the area : take shelter immediately.

The easiest way to remember the difference is a Watch means to watch the sky (conditions are favorable). A warning means, head the warning and take shelter now.

Taking Shelter:

When the sirens are going off take shelter immediately.

First of all, if you live in a mobile home "get out", there are no safe places to seek shelter in a mobile home. If you live in a mobile home, when you hear that we are under a tornado watch, you should leave the mobile home and go to a friends house or a safe structure and wait out the storm. If you live in a mobile home and the sirens sound, get out and get to the lowest lying area, a ditch or a ravine.

If a tornado warning is issued and time does not permit residents to travel to a shelter, the best protection during a tornado is to quickly go to the lowest level in the building.

The safest place to be is in the basement under something sturdy

If there is no basement, seek shelter in a small interior room in the middle of the building, such as a closet or bathroom.

Stay away from outside doors and windows.

Remain in shelter until the storm has passed or the all clear is given from authorities.

[| Back to the EMERGENCY home page |](#)



Thunderstorms and Lightning (Also see [Sirens](#))

[| FEMA Web info |](#) [| Lightning safety for Kids |](#) [| Thunderstorm Safety Guide |](#)

Some thunderstorms can be seen approaching, while others hit without warning. It is important to learn and recognize the danger signs and to plan ahead.

BEFORE

Learn the thunderstorm danger signs

- Dark, towering, or threatening clouds
- Distant lightning and thunder

Have disaster supplies on hand

- Flashlight with extra batteries
- Portable, battery-operated radio and extra batteries
- First aid kit and manual
- Emergency food and water
- Non electric can opener
- Essential medicines
- Cash and credit cards
- Sturdy shoes



Check for hazards in the yard

Dead or rotting trees and branches can fall during a severe thunderstorm and cause injury and damage

- Make sure that all family members know how to respond after a thunderstorm
- Teach family members how and when to turn off gas, electricity and water

- Teach children how and when to call 9-1-1, police, fire department, and which radio station to tune for emergency information

Severe Thunderstorm Watches and Warnings

A severe thunderstorm watch is issued by the National Weather Service when the weather conditions are such that a severe thunderstorm (damaging winds 58 miles per hour or more, or hail three-fourths of an inch in diameter or greater) is likely to develop. This is the time to locate a safe place in the home and tell family members to watch the sky and listen to the radio or television for more information.

A severe thunderstorm warning is issued when a severe thunderstorm has been sighted or indicated by weather radar. At this point, the danger is very serious and everyone should go to a safe place, turn on a battery-operated radio or television, and wait for the "all clear" by the authorities.

Learn how to respond to a tornado and flash flood.

Tornadoes are spawned by thunderstorms and flash flooding can occur with thunderstorms. When a "severe thunderstorm warning" is issued, review what actions to take under a "tornado warning" or a "flash flood warning."

Develop an emergency communication plan

In case family members are separated from one another during a thunderstorm (a real possibility during the day when adults are at work and children are at school), have a plan for getting back together.

Ask an out-of-state relative or friend to serve as the "family contact". After a disaster, it's often easier to call long distance. Make sure everyone knows the name, address, and phone number of the contact person.

Contact your local emergency management office or American Red Cross chapter for more information on thunderstorms and lightning.

DURING

If indoors

- Secure outdoor objects such as lawn furniture that could blow away or cause damage or injury. Take light objects inside
- Shutter windows securely and brace outside doors
- Listen to a battery operated radio or television for the latest storm information
- Do not handle any electrical equipment or telephones because lightning could follow the wire. Television sets are particularly dangerous at this time
- Avoid bathtubs, water faucets, and sinks because metal pipes can transmit electricity

If outdoors

- Attempt to get into a building or car
- If no structure is available, get to an open space and squat low to the ground as quickly as possible. (If in the woods, find an area protected by low clump of trees--never stand underneath a single large tree in the open.) Be aware of the potential for flooding in low-lying areas

- Crouch with hands on knees
- Avoid tall structures such as towers, tall trees, fences, telephone lines, or power lines
- Stay away from natural lightning rods such as golf clubs, tractors, fishing rods, bicycles, or camping equipment
- Stay from rivers, lakes, or other bodies of water
- If you are isolated in a level field or prairie and you feel your hair stand on end (which indicates that lightning is about to strike), bend forward, putting your hands on your knees. A position with feet together and crouching while removing all metal objects is recommended. Do not lie flat on the ground

If in a car

- Pull safely onto the shoulder of the road away from any trees that could fall on the vehicle
- Stay in the car and turn on the emergency flashers until the heavy rains subside
- Avoid flooded roadways

Estimating the Distance from a Thunderstorm

Because light travels much faster than sound, lightning flashes can be seen long before the resulting thunder is heard. Estimate the number of miles you are from a thunderstorm by counting the number of seconds between a flash of lightning and the next clap of thunder. Divide this number by five.

Important: You are in danger from lightning if you can hear thunder. Knowing how far away a storm is does not mean that you're in danger only when the storm is overhead.

Hail

Hail is produced by many strong thunderstorms. Hail can be smaller than a pea or as large as a softball and can be very destructive to plants and crops. In a hailstorm, take cover immediately. Pets and livestock are particularly vulnerable to hail, so bring animals into a shelter.

AFTER

Check for injuries.

A person who has been struck by lightning does not carry an electrical charge that can shock other people. If the victim is burned, provide first aid and call emergency medical assistance immediately. Look for burns where lightning entered and exited the body. If the strike cause the victim's heart and breathing to stop, give cardiopulmonary resuscitation (CPR) until medical professionals arrive and take over.

Remember to help your neighbors who may require special assistance--infants, elderly people, and people with disabilities.

Report downed utility wires.

Drive only if necessary. Debris and washed-out roads may make driving dangerous.

Flash Floods

During a thunderstorm be aware that low lying areas are prone to flash flooding. Never drive into water on the road. Many people do not realize the power of flowing water. It takes less than two feet of water to make a car float. Once floating, the car will be swept downstream and will often overturn, trapping occupants inside. If your car stalls in high water, abandon it immediately - MOVE TO HIGHER GROUND.

During the 1993, 1994, 1995 and 1996 floods, 35 Missourians died when they drove their cars into flash flooding or rivers. Many of these deaths could have been avoided if people had realized the dangers of wading, bicycling or driving vehicles across flooded roads where there were rising or swift moving waters.

[| Back to the EMERGENCY home page |](#)



Tornado Information (Also see [Sirens](#))

[| FEMA Web info | Tornado Safety | Tornado Facts |](#)

Most tornadoes occur between March and September, but they can strike at any time, day or night. Stay alert during severe thunderstorms. Watch for a spinning, funnel-shaped cloud, or listen for a sound like the roar of a speeding train. Wherever you go, be aware of where you might take shelter. Stay tuned to your local radio station for tornado information. It could save your life.

[Tornado Myths](#) | [What to do](#) | [Facts & Figures](#) | [Statistics](#)

Tornado Myths & Facts

- **Myth:** Areas near rivers, lakes and mountains are safe from tornadoes.
- **Fact:** No place is safe from tornadoes. They can cross rivers, travel up mountains, and roar through valleys.
-
- **Myth:** Low pressure with a tornado causes building to "explode" as the tornado passes overhead.
- **Fact:** Violent winds and debris slamming into buildings cause most structural damage.
-
- **Myth:** Windows should be opened before a tornado to equalize pressure and minimize damage.

- **Fact:** Opening windows ALLOWS damaging winds to enter the structure. Leave the windows alone; instead, go to a safe place immediately.

What to do in a tornado situation

Tornado Watch:

A WATCH means "Watch" the sky. Weather conditions are right for tornadoes.

Tornado Warning:

A WARNING means a tornado has been sighted or picked up on radar.

Take Cover Immediately!

On The Road:

If you are caught on the road in a tornado, leave your car immediately. Never try to outrun a tornado. Do get inside a building, if you have time. If not, lie flat in a ditch or ravine, and cover your head with your arms. Don't take cover under the car.

At Home:

If you are home when a tornado strikes, go to your basement, and take cover. If you don't have a basement, go to an interior room on the lowest floor, like a closet or a bathroom with no windows. It's vital to stay away from windows. Don't take the time to open them before taking cover.



Mobile Home:

Even the most securely anchored mobile home is not safe in a tornado. If a tornado warning is issued for your area, leave your mobile home immediately. DON'T get under your mobile home or try to outrun the tornado in your car. DO move to a nearby permanent shelter, or take cover in a ditch or ravine.

Outside:

If you're caught outside in a tornado, take cover in a ditch or ravine immediately. Lie flat with your arms over your head. If you can, wrap something around your body like a blanket or sleeping bag. Do not get under your car or camper or go into a grove of trees.

Safety Drills:

Do you know what to do if a tornado threatens your school, factory or office? In a tornado, take cover against a wall in the center of the building, below ground level, if possible. Stay away from windows, and avoid large open spaces like auditoriums and cafeterias. If there are no tornado drills at your school or office, suggest them. Safety drills can save lives.

Twister Facts & Figures

The following twister phenomenon came from "The Tornado Project" homepage at <http://www.tornadoproject.com/>

The region of the world where most tornadoes occur is in the central plains region of the United States.

Generally, tornadoes move from a southwesterly direction to the northeast, parallel to the cold front line.

Tornadoes can occur at all hours, but they are most likely to develop between 3-7 p.m., when the weather is hottest.

A tornado's path length ranges from 10-40 miles, with an average length of 16 miles. However, the Tri-State tornado of March 18, 1925 rampaged 219 miles in an almost straight line across three states.

A tornado's vortex produces the strongest wind speeds of any surface wind. Recent research indicates most tornadoes have wind speeds of about 112 mph.

The average forward speed of a tornado is 25-40 mph. Speeds can range from as slow as 5 mph up to 125 mph.

Missouri Severe Weather Statistics

		2002	2001	2000	1999	1998
Tornadoes	Total	29	39	27	41	23
	Deaths	4	1	0	0	0
	Injuries	56	9	0	12	18
Flash Floods or Floods	Deaths	3	3	2	4	3
	Injuries	7	6	0	3	2
Lightning	Deaths	5	0	0	0	0
	Injuries	1	0	4	1	2
Thunderstorm Winds	Deaths	0	0	0	0	0
	Injuries	1	36	6	11	4
Combined Totals	Deaths	12	4	2	4	13
	Injuries	65	51	10	27	24

| [Back to the EMERGENCY home page](#) |



Utilities (*Natural Gas* / *Electricity* / *Water*)

Natural Gas

- Natural gas leaks can cause an explosive and flammable atmosphere inside a building.

- If you smell gas, hear gas escaping, see a broken gas line, or if you suspect a leak, shut off the main valve and open all windows and doors.
- Never use candles or matches if you suspect a leak. Do not turn on electrical switches or appliances.
- Identify the main shutoff valve, which is located on the gas line coming into the main gas meter. This is usually on the exterior of your home or building, or in an external closet. Your main valve may look like this:

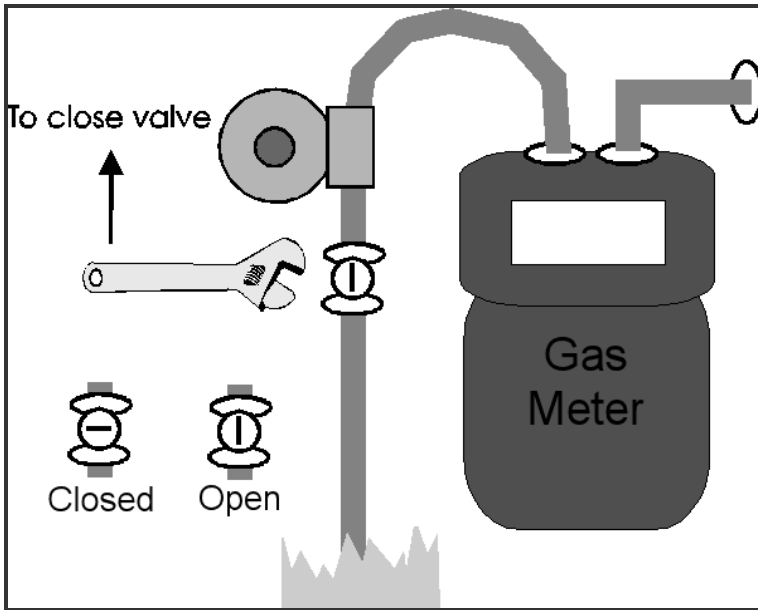

- To turn gas off, give the valve a quarter turn in either direction. When the lever crosses the direction of the pipe the gas is off.
- Keep a crescent wrench or gas shut-off tool nearby to turn the lever.
- Once you turn off the gas, never attempt to turn it back on yourself. Wait for your utility company to do it, but be aware that it may take several days for it to be turned back on.

[Back to Utilities](#)

Electricity

Electrocution can result from direct contact with live wires or anything that has been energized by these wires.

Locate your home's main electric switch, which is normally in the garage or outdoors, where the power lines enter the home. The panel box may have a flip switch or pull handle on a large circuit breaker.

Shut off electricity when:

- Arcing or burning occurs in electrical devices.
- There is a fire or significant water leak.
- you smell burning insulation.
- The area around switches or plugs is blackened and/or hot to the touch.
- A complete power loss is accompanied by the smell of burning material.

[Back to Utilities](#)

Water

Water leaks can cause property damage and create an electrocution hazard.

- Shut off the water when there is a leak inside the building.
- The water shutoff is usually located in the basement, garage, or where the water line enters the home. The water shutoff is located on a riser pipe and is usually a red or yellow wheel. Turn wheel clockwise to shut off.

[Back to Utilities](#)

| [Back to the EMERGENCY home page](#) |